



2000 IPS™ (Integrated Positioning System) Car Seat

CSI-2000



EU Authorized Representative  
BS Partnership Cardiff CF23 6N UK



**WARNING!**

Read ALL instructions before using this product!

## Table of Contents

Important Safety Information.....	3
Vehicle Seat Belt Compatibility .....	6
Vehicle Seating Positions.....	7
Car Seat Components .....	8
Installation Instructions .....	10
Vehicle Lap and Shoulder Belt (Recommended) .....	10
Vehicle Lap and Shoulder Belt-Requires Locking Clip .....	12
Vehicle Lap Belt Only .....	13
Aircraft Installation .....	14
Installing the Tether Strap .....	15
LATCH Vehicle Installation .....	16
Non-LATCH Vehicle Installation .....	18
Components and Adjustments .....	19
Operating the Harness Buckle .....	19
Checking the Harness Height .....	19
Adjusting the Harness Height .....	20
Adjusting the Harness Fit .....	20
Adjusting the Chest Clip .....	21
Adjusting the Head Pads .....	21
Adjusting the Lateral Positioning Pads .....	21
Securing the User in the Restraint .....	22
Care and Maintenance .....	23
Removing the Cover .....	23
Cleaning the Fabric .....	23
Cleaning the Harness and Buckle .....	23
Product Registration .....	24
Warranty .....	24



**WARNING!**  
DEATH or SERIOUS INJURY can occur.

**MODEL # CSI-2000 Positioning Restraint System:** Use only with individuals who weigh between 20 and 102 pounds (9.1— 46.3 kg) and whose height is less than 60 inches (152.4 cm).

- Snugly adjust the belts provided with this Positioning Restraint System around the user. A snug strap should not allow any slack. It lies in a relatively straight line without sagging. It does not press on the user's flesh or push the user's body into an unnatural position.
- Secure the top anchorage strap (tether) provided with this Positioning Restraint System.
- Secure this Positioning Restraint System with your vehicle's seat belt.
- **Read and follow all instructions** on this Positioning Restraint System and in the written instructions located on the side of the restraint.
- **Register your Positioning Restraint System** by completing and sending in the registration card. Although restraint systems undergo testing and evaluation, it is possible that a restraint could be recalled for safety reasons. You must register this restraint to be reached in the case of recall. Send your name, address, email (optional), and the restraint's model and serial number and manufacturing date to Inspired by Drive, 11724 Willake Street, Santa Fe Springs, CA 90670 USA or call 800-454-6612. For recall information, call the U.S. Government's Vehicle Safety Hotline at 1-888-327-4236 (TTY: 1-800-424-9153), or go to <http://www.NHTSA.gov>.
- This Positioning Restraint System is designed to fit a wide range of individuals. To ensure a proper fit for the user, it is important that the restraint be correctly set up and installed before using it for the first time.
- Use this Positioning Restraint System in the forward-facing position only. This restraint is not designed for use in a rear-facing position. The American Academy of Pediatrics recommends forward facing only after one year old.
- Do not use this Positioning Restraint System with your vehicle's lower anchor LATCH connector system. Use only the vehicle's seat belts for installation. Upper LATCH anchor points are used to secure the tether.

## Important Safety Information (continued)

- **Do not use this Positioning Restraint System in the front seat of a vehicle with a passenger air bag unless the air bag is turned off. DEATH or SERIOUS INJURY can occur.** According to accident statistics, individuals are safer when properly restrained in the rear seat than in the front seat. Regardless of seating position, the Federal government recommends that all children under twelve years of age ride in the rear seat.
- When using this Positioning Restraint System in a vehicle with side air bags, refer to the vehicle owner's manual for child restraint installation instructions and precautions.
- Do not use this Positioning Restraint System with vehicle seats that face to the side or rear or with vehicle seats with backs that can fold forward in a crash or sudden stop. Check your owner's manual or with your dealer if you are not sure.
- Read the section on **vehicle seat belt compatibility** to determine the type of seat belts that may be used with this Positioning Restraint System.
- Do not route the vehicle seat belt over the user while using this Positioning Restraint System.
- The harness assembly is for use only with the CSI-2000 Positioning Restraint System. Do not use the harness independently of the seat.
- If your Positioning Restraint System becomes badly worn or damaged, or is involved in an accident, regardless of speed and regardless how minor, your restraint system may no longer be effective and should immediately be replaced.
- Secure this Positioning Restraint System even when it is not occupied; in a crash, an unsecured restraint may injure vehicle occupants.
- The metal parts on a restraint system can heat up if the vehicle is parked in the sun. To avoid injury to the occupant, always check that the metal parts are not too hot before putting the occupant in the seat. We recommend if you park in the sun, covering your seat with a blanket or towel to help keep the metal parts from heating up.
- Never leave children unattended in the vehicle, even if they are secured in a restraint system. Children could be seriously or fatally injured from excessive exposure to extreme heat or cold.

## Important Safety Information (continued)

- Do not leave loose objects in the passenger compartment of your vehicle. In the event of an accident, these objects can become projectiles and cause serious injury or death.

### **IMPORTANT SAFETY INFORMATION:**

**MODEL # CSI-2000 Positioning Restraint System:** This restraint system conforms to all applicable Federal motor vehicle safety standards. **This restraint is certified for use in motor vehicles and aircraft.**

## Vehicle Belt Compatibility

**IMPORTANT:** Vehicle seats and safety seat belts differ from vehicle to vehicle. Always refer to your vehicle owner's manual or call the vehicle manufacturer for specific information about the use of child restraint systems in your vehicle. Some vehicles may have seating positions or seat belts which are not compatible with this Positioning Restraint System, or any other restraint system.

### VEHICLE SEAT BELTS THAT CAN BE USED:

- **Continuous-loop lap-shoulder belts with a sliding latch plate.** This type of seat belt consists of continuous webbing that is bolted to the vehicle on one end and has a retractor on the other end. The latch plate (the "male" part of the seat belt buckle) slides freely along the webbing to form a lap belt and a shoulder belt when attached to the buckle.
- **Combination lap-shoulder belts with a locking latch plate.** This type of seat belt has a latch plate (the "male" part of the seat belt buckle) that locks into place for securing the restraint system.
- **Lap belts with automatic locking retractors.** These lap belts automatically lock to whatever length they have been pulled to, after which they can only be reset by retracting the belt completely.
- **Lap belts with a locking latch plate.** This type of seat belt stays locked after the seat belt is tightened by pulling the free end.

### VEHICLE SEAT BELTS THAT CANNOT BE USED:

- Seat belts with the top and/or bottom anchor attached to the vehicle door.
- Lap belts with an emergency locking retractor (ELR), which means that the lap belt will only lock in the event of a sudden stop or crash.
- Motorized seat belts that automatically surround the passenger when the door is closed.
- Combination lap and shoulder belts with a "sewn lock plate". The lap belt is sewn to the side of the lock plate (the "male" part of the seat belt buckle), while the shoulder belt is sewn to the top of the lock plate. Each belt feeds into a separate emergency-locking retractor prohibiting proper control of the seat belt tension.

## Vehicle Seating Positions

- This Positioning Restraint System must **ONLY** be used in **forward-facing vehicle seats**.
- This Positioning Restraint System is to be used **ONLY** in the **forward-facing position**.
- This Positioning Restraint System **CANNOT** be used in the following seating positions:
  - Rear-facing vehicle seats, such as those in some vans or buses.
  - Side-facing vehicle seats, such as those in some vans and pick-up trucks.
  - Flip-down vehicle seats, often referred to as “jump-seats.”

**NOTE: According to research sponsored by the National Highway Traffic Safety Administration, children are significantly safer when properly restrained in the back seat, compared to the front seat.**

## Car Seat Components



1. Adjustable Head Pads (or Headwings)
2. Shoulder Harness Pads
3. Lateral Positioning Pads (under cover)
4. Chest Clip
5. Buckle
6. Crotch Strap Pad
7. Harness Straps and Clip
8. Metal Side Tubes
9. Buckle Adjustment Strap
10. Tether Strap



## Car Seat Components (continued)



## Installation

The CSI-2000 Positioning Restraint System must be installed with a Tether Strap which is included. The tether strap must be attached properly to a LATCH top tether anchor or must be bolted into a structurally secure location in the vehicle. See “Installing the Tether Strap.”

Use of the tether improves the safety of the Positioning Restraint System and reduces the risk of injury.

### Vehicle Lap and Shoulder Belt (Recommended Method)

This is the recommended method for installing the Positioning Restraint System and is used in vehicles equipped with an **Automatic Locking Retractor (ALR)** function. The ALR allows the user to lock the retractor at a set position (also called **child restraint mode**) used for **securing child seats**. ALR mode is activated by extending the retractor all the way out until a “click” is heard, next let the seat belt (webbing) retract into the retractor to the desired length and stop the belt at that point. The retractor locks and will not let the belt lengthen at that point (only retract).

1. Place the Positioning Restraint System in a forward facing position on the vehicle seat. **If the front edge of the restraint extends more than 1” (25mm) beyond the front edge of the seat, then the vehicle seat is too shallow to properly support the restraint system. If this is the case, do not install.**
2. Attach the tension adjuster hooks of the tether to the upper anchor points located on the sides of the Positioning Restraint System. **See Installing the Tether Strap.**
3. Attach the tether loosely to an approved anchor point in the vehicle. In cars built after 2002, approved anchor points can be identified by this symbol. Refer to your vehicle owner’s manual if needed.
4. Verify that the seat belt in the vehicle can be used with the Positioning Restraint System. **See Vehicle Seat Belt Compatibility.**
5. Pull the seat belt out completely to engage the retractor, then route the belt between the back of the restraint and the metal tubes which are located along the sides of the Positioning Restraint System.



Anchor point symbol

## Installation (continued)

6. Make sure that the seat belt is not twisted, then buckle in place.
7. Make sure the restraint system is flat against the vehicle seat's bottom and back. Use your hands to apply firm pressure to the restraint, pushing it into the vehicle backrest—or place your knee on the restraint and push down with all your weight—while pulling on the vehicle seat belt and removing all slack from it.
8. Check to make sure the tether strap is not twisted and then tighten to secure the upper portion of the restraint. If the vehicle does not have a top tether anchor point, it will be necessary to use a bolt-in anchor mounting bracket. **See Non-LATCH Vehicle Installation.**
9. **DO NOT USE** this restraint without the tether strap properly installed.
10. Verify that the vehicle seat belt is tight and that the Positioning Restraint System is secure. When properly installed, the restraint will not move more that 1" (25mm) from side to side and or front to back. If the restraint is not secure, repeat steps 5 – 8.

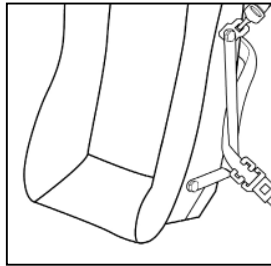

### **Vehicle Lap and Shoulder Belt – Requires Locking Clip**

This method of installation is required when installing the Positioning Restraint System in a vehicle with an emergency locking retractor (ELR) type of seat belt. **Emergency Locking Retractor (ELR)** function allows the occupant to have free movement while buckled up, but in the event of an emergency situation, such as heavy braking or collision, the retractor instantly locks securing the occupant. This type of seat belt is “webbing sensitive,” meaning that any sudden movement of the webbing (the seat belt strap) causes the retractor to instantly lock. **A locking clip is required to achieve the proper tension when using this belt type to secure a restraint.**

## Installation (continued)

1. Place the Positioning Restraint System in a forward facing position on the vehicle seat. **If the front edge of the restraint extends more than 1" (25mm) beyond the front edge of the seat, then the vehicle seat is too shallow to properly support the restraint system. If this is the case, do not install.**
2. Attach the tension adjuster hooks of the tether to the upper anchor points located on the sides of the Positioning Restraint System. **See Installing the Tether Strap.**
3. Attach the tether loosely to an approved anchor point in the vehicle. In cars built after 2002, approved anchor points can be identified by this symbol. Refer to your vehicle owner's manual if needed.



Anchor point symbol

4. Verify that the seat belt in the vehicle can be used with the Positioning Restraint System. **See Vehicle Seat Belt Compatibility.**

5. Pull the seat belt out completely then route the belt between the back of the restraint and the metal tubes which are located along the sides of the Positioning Restraint System.
6. Make sure that the seat belt is not twisted, then buckle in place.
7. Make sure the restraint system is flat against the vehicle seat's bottom and back. Use your hands to apply firm pressure to the restraint, pushing it into the vehicle backrest or place your knee on the restraint and push down with all your weight while pulling on the vehicle seat belt and removing all slack from it.

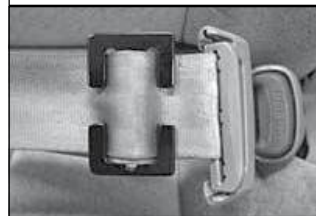
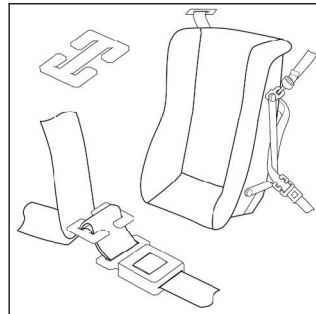

Figure 3: Combination Lap/Shoulder Belt with Locking Clip

8. With one hand, firmly hold the shoulder and lap portions of the seat belt together immediately behind the latch, then release the seat belt latch from the buckle.
9. Fold the webbing and thread it through the locking clip, one side at a time keeping the locking clip as close as possible to vehicle belt latch – no further than ½" (12mm) away. **See Figure 3.**

## Installation (continued)

10. Buckle the seat belt to see that the clip has been correctly installed, with all slack webbing gone and the restraint tightly in place.
11. Check to make sure the tether strap is not twisted and then tighten to secure the upper portion of the restraint. If the vehicle does not have a top tether anchor point, it will be necessary to use a bolt-in anchor mounting bracket. **See Installation Without LATCH Top Tether Anchors.**
12. **DO NOT USE** this restraint without the tether strap properly installed.
13. Verify that the vehicle seat belt is tight and that the Positioning Restraint System is secure. When properly installed, the restraint will not move more than one inch (1") from side to side and or front to back. If the restraint is not secure, repeat steps 5 – 11.

### Vehicle Lap Belt Only

1. Place the Positioning Restraint System in a forward facing position on the vehicle seat. **If the front edge of the restraint extends more than 1" (25mm) beyond the front edge of the seat, then the vehicle seat is too shallow to properly support the restraint system. If this is the case, do not install.**
- 
2. Attach the tension adjuster hooks of the tether to the upper anchor points located on the sides of the Positioning Restraint System. **See Installing the Tether Strap.**
  3. Attach the tether loosely to an approved anchor point in the vehicle. In cars built after 2002, approved points can be identified by this symbol. Refer to your vehicle anchor owner's manual if needed.
  4. Check the seat belt in the vehicle to verify that it can be used with the Positioning Restraint System. **See Vehicle Seat Belt Compatibility.** This restraint cannot be used with lap belts with an emergency locking retractor (ELR), which means that the lap belt will only lock in the event of a sudden stop or crash.
  5. Pull the lap belt out completely, then route the belt between the back of the restraint and the metal tubes which are located along the sides of the Positioning Restraint System.

Figure 4: Lap Belt Only

## Installation (continued)

6. Make sure that the seat belt is not twisted, then buckle in place.
7. Make sure the restraint system is flat against the vehicle seat's bottom and back. Use your hands to apply firm pressure to the restraint, pushing it into the vehicle backrest or better yet, place your knee on the restraint and push down with all your weight while pulling on the vehicle seat belt and removing all slack from it.
8. Check to make sure the tether strap is not twisted and then tighten to secure the upper portion of the restraint. If the vehicle does not have a top tether anchor point, it will be necessary to use a bolt-in anchor mounting bracket. **See Installation Without LATCH Top Tether Anchors.**
9. **DO NOT USE** this restraint without the tether strap properly installed.
10. Verify that the vehicle seat belt is tight and that the Positioning Restraint System is secure. When properly installed, the restraint will not move more than 1" (25mm) from side to side and or front to back. If the restraint is not secure, repeat steps 4 - 7.

### Aircraft Installation

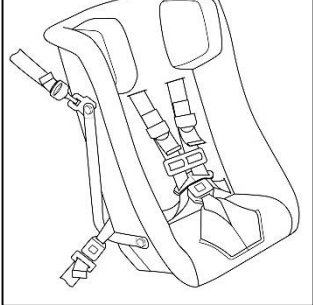
1. Place the Positioning Restraint System in a forward facing position on the vehicle seat. **If the front edge of the restraint extends more than 1" (25mm) beyond the front edge of the seat, then the vehicle seat is too shallow to properly support the restraint system. If this is the case, do not install.**
2. Pull the lap belt out completely, then route the belt between the back of the restraint and the metal tubes which are located along the sides of the Positioning Restraint System.
3. Make sure that the seat belt is not twisted, then buckle in place.
4. Make sure the restraint system is flat against the vehicle seat's bottom and back. Use your hands to apply firm pressure to the restraint, pushing it into the vehicle backrest or better yet, place your knee on the restraint and push down with all your weight while pulling on the vehicle seat belt and removing all slack from it.
5. Verify that the vehicle seat belt is tight and that the Positioning Restraint System is secure. When properly installed, the restraint will not move more than 1" (25mm) from side to side and or front to back.

## Installation the Tether Strap - LATCH Installation

The CSI-2000 Positioning Restraint System includes a top anchorage strap, known as a tether. The tether is engineered to make attachment to the upper anchor points of the LATCH system easier.

LATCH (**L**ower **A**nchor and **T**ethers for **C**hildren) anchors have been required on all US passenger vehicles since 2002.

**IMPORTANT:** Read these instructions completely and check your vehicle owner's manual prior to installation to determine the proper attachment method and locations to position this Positioning Restraint System.

### IMPORTANT SAFETY WARNINGS:

**The tether must be used when installing the Positioning Restraint System. Use of the tether improves safety and reduces the risk of injury.**

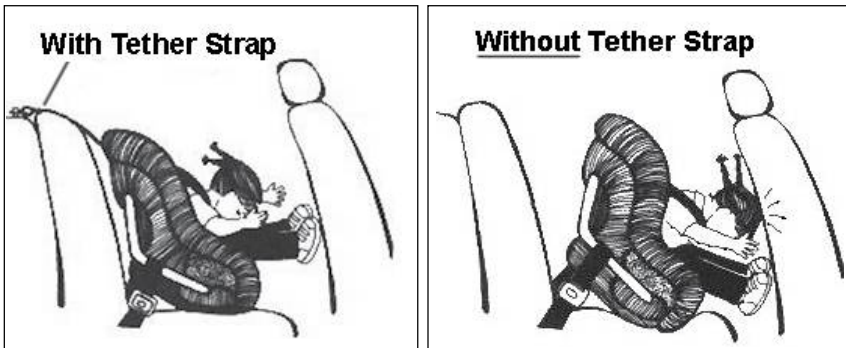

- The tether must only be attached to tether anchor points designated as tether anchor points by the vehicle manufacturer. This icon is used by vehicle manufacturers to identify the LATCH anchors. Use of other locations is not approved or permitted.



Anchor point symbol

## Installing the Tether Strap (continued)

- An incorrectly mounted restraint system may come loose during an accident which could result in serious injury or death to the user.
- Damaged or impact damaged restraint systems should be replaced immediately.
- **For occupants over 80 lb (36 kg), BOTH tether hooks must be used. Each hook must be attached to a separate tether anchor. A single tether anchor is not strong enough to support weights in excess of 80 lb (36 kg).**

### Installing the Tether with LATCH

1. The tether is not attached during shipping. Locate the tether and remove it from its plastic bag.
2. The tether has two (2) tension adjuster hooks (one located on each end of the tether) and two (2) “free-floating” tether hooks. **See Figure 5.**

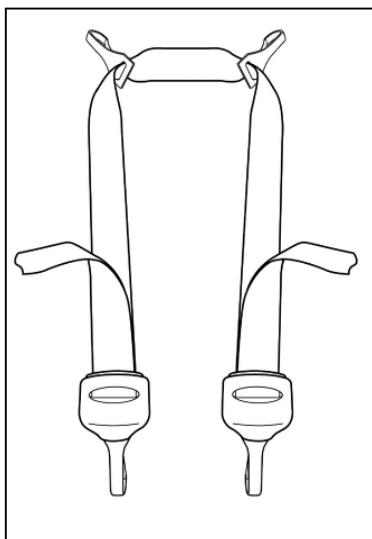

Free-floating tether hooks to attach to vehicle's LATCH upper anchor points

Tension Adjuster Hooks

Figure 5: Illustration of Tether



## Installing the Tether Strap (continued)

3. Attach one tension adjuster hook to the upper side anchor bracket located on each side of the restraint. **See Figure 6.**

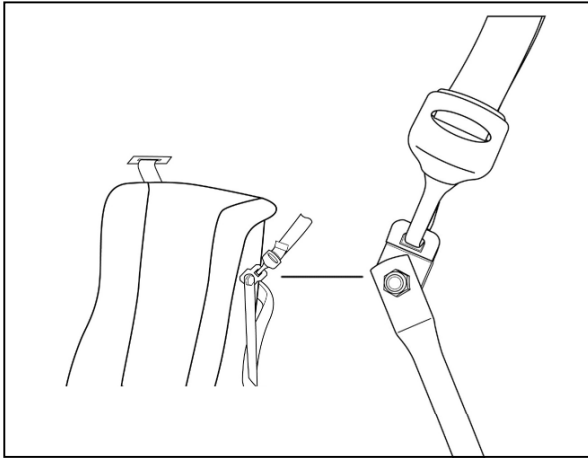

Figure 6: Attaching tether to upper side anchor bracket

4. Attach the tether hook(s) to the vehicle's tether anchor(s). The primary tether anchor to use will be located immediately behind the restraint.
  - **For individuals less than 80 lb (36 kg):** attach one (1) tether hook to the tether anchor immediately behind the restraint. **See Figure 7.**

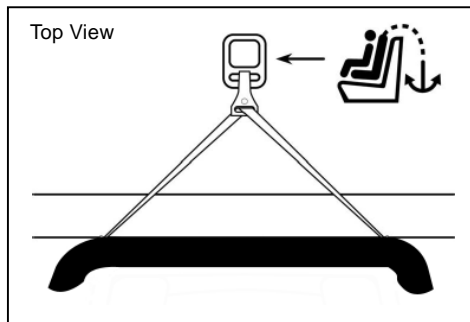
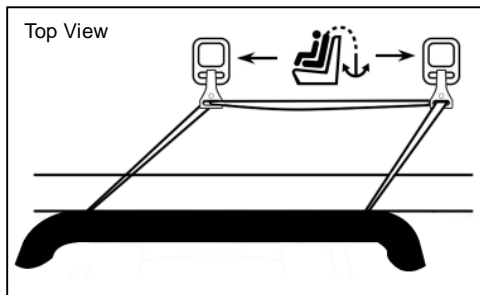

Figure 7: Single hook attachment for individuals under 80 lb (36 kg)

## Installing the Tether Strap (continued)

- **For individuals greater than 80 lb (36 kg):** use two (2) tether hooks attaching one (1) tether hook to the tether anchor immediately behind the restraint AND one (1) tether hook to the closest adjacent tether anchor. **See Figure 8.**



5. Remove any slack in the tether by pulling the loose ends of the tether through the tension adjuster hooks.
6. Verify that the tether is appropriately attached and tensioned as noted above.

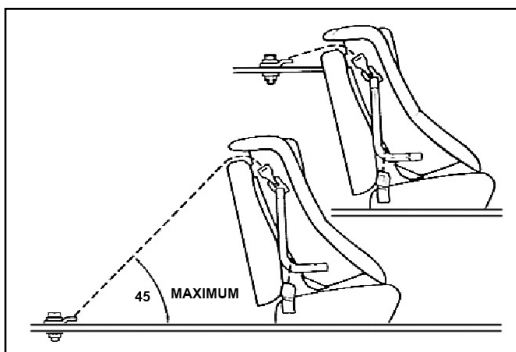

Figure 9: Tether Anchoring Methods

**Non-LATCH Vehicle Installation:** If the desired seating position in the vehicle does not have a LATCH top tether anchor (which may be the case for vehicles that were made before 2002), it is necessary to use a bolt-in anchor mounting bracket to secure the tether strap. Contact Inspired by Drive directly for more details on acquiring an anchor mounting bracket (800) 454-6612

## Components and Adjustments

The CSI-2000 Positioning Restraint system includes the following standard components:



A. 5-Point Safety Harness

B. Shoulder Harness Pads

C. Adjustable Head Pads/Wings

D. Crotch Strap Pad

E. Lateral Positioning Pads (inside)

F. Tether Strap Kit

### Operating the Harness Buckle

- To release, press the red button on the harness buckle.
- To close, insert one metal latch into the harness buckle until it clicks. Repeat for the other metal latch.
- Always make sure both latches are properly fastened in the harness buckle when securing a user.
- Never lubricate the harness buckle.

### Checking the Harness Height

1. Place the user in the Positioning Restraint System and properly secure with the harness.
2. Note the position of the harness relative to the shoulder of the user.
  - Harness straps should be inserted in the nearest slot at or above the user's shoulder.
  - If the harness height is correct, the restraint can be used with no further adjustment.
  - If the height of the user's shoulder is above the harness it will be necessary to adjust the harness. **See Adjusting the Harness Height.**

## Components and Adjustments (continued)

### Adjusting the Harness Height

1. To adjust the harness, it is necessary to remove the Positioning Restraint System from the vehicle.
2. Place the user in the restraint and identify the closest harness slot at or above the height of the user's shoulder.
3. Remove the user from the restraint prior to making any adjustments to the harness.
4. Locate the metal bracket securing the top of the harness along the back side of the restraint and pull it away to expose 3"- 4" (76.2 - 101.6 mm) of webbing.
5. Turn the metal bracket so the short side will fit through the slot in the back of the restraint and push it through the slot as well as the cover.
6. Reposition the harness to the correct slot and reverse the process to reinstall the harness.
7. After repositioning the harness, make sure the metal bracket is flat against the back of the restraint to prevent it from slipping out.



### Adjusting the Harness Fit

1. With the user in the restraint, check the location of the buckle.
2. The buckle should be positioned at the level of the user's hips, not over the stomach area.
3. If necessary, the position of the buckle can be changed by adjusting the metal bracket on the bottom of the restraint.
4. The shoulder straps can be independently adjusted by pressing the gray button on the tension adjuster then adding or removing slack in the webbing as necessary to obtain a snug fit.
5. A snug strap should not allow any slack. It lies in a relatively straight line without sagging. It does not press on the user's flesh or push the user's body into an unnatural position.

## Components and Adjustments (continued)

### Adjusting the Chest Clip

**Important:** The correct height for the chest clip is at the middle of the chest level with the armpit.

1. The chest clip keeps the shoulder straps of the harness from sliding down off the shoulders.
2. The chest clip is fastened by fitting the two halves together. The chest clip is properly secured when a click is heard.
3. The chest clip is opened by squeezing the middle tab and pulling the two pieces apart.
4. With the harness properly attached and the chest clip fastened, the chest clip should be positioned at the middle of the chest, in line with the armpits of the user.

### Adjusting the Head Pads

1. The Positioning Restraint System has adjustable head pads.
2. Determine if the head pad(s) need to be adjusted.
3. Locate the plastic ball on the lanyard that is located behind and to the side of each head pad.
4. Press the button on the plastic ball, sliding the head pad along the lanyard to the desired height, then release the button to secure the head pad into position.

### Adjusting Lateral Positioning Pads

1. The Positioning Restraint System comes standard with four flat positioning pads which are designed to be adjusted to offer the user more or less support as needed. The pads are located under the cover on the sides of the restraint.
2. The lateral positioning pads can be used to decrease the inside width of the car seat if the seat is too wide.
3. Use only as many pads as needed for a correct fit. As a guideline, you should have about one inch of space on either side of the user and the restraint seat cover.
4. To adjust pads, lift the upholstery cover from the sides of the restraint shell. The pads are located between the inside of the plastic shell and the cover.
5. Stretch the upholstery cover back over the pads and the edge of the shell.

## Securing the User in the Restraint

Once the CSI-2000 Positioning Restraint System has been properly fitted and installed in the vehicle, follow these instructions to secure the user in the restraint.

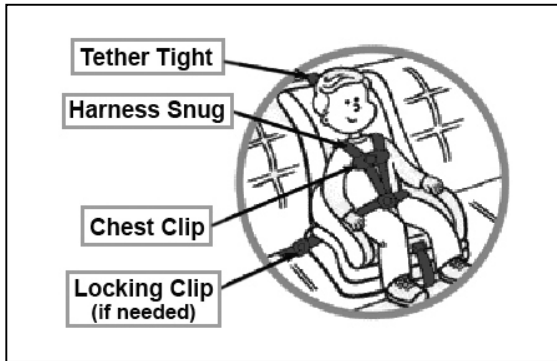

1. Open the harness and move the harness straps to the side of the restraint.
2. Place the user in the restraint with his/her back positioned against the back rest in as upright a position as possible.
3. Verify that the harness straps are located in the slots above, but closest to the top of the user's shoulders.
4. If the harness straps are not in the appropriate position, move them according to the instructions provided in **Adjusting the Harness Height**.
5. Place the harness shoulder straps over each of the user's shoulders making sure that the straps are not twisted or binding on any object.
6. Fasten the metal latch on each shoulder strap securely into the buckle.
7. Fasten the plastic chest clip and position it in the middle of the users chest — aligned with the armpits of the user.
8. Check to ensure the harness fit is snug. If needed, adjust the harness fit as noted in **Adjusting the Harness Fit**.
9. To remove the user from the restraint system, reverse steps outlined above.

## Care and Maintenance

### Cleaning the Cover

- Spot clean with upholstery shampoo, foam from a mild detergent, or mild dry cleaning solvent. Do not saturate with liquid.
- Pile fabrics may require brushing to restore appearance.
- To clean the harness straps, use a sponge, warm water and mild detergent. Do not use abrasive cleansers.
- To clean the buckle, use a damp cloth and mild detergent. Do not use abrasive cleansers.
- Do not disassemble the harness.

### Removing the Cover

1. Remove the soft support pads (if present) by releasing the lanyards from the underside of the cover.
2. Open the chest retainer clip and release the metal latches from the buckle.
3. Remove harness completely by first locating the metal bracket securing the top of the harness along the back side of the child restraint. Pull it away to expose 3 to 4 inches (76.2 to 101.5 mm) of the webbing.
4. Turn the metal bracket so the short side will fit through the slot in the back of the child restraint and push it through the slot and the cover (from back to front).
5. Push those same metal brackets through the lower side harness slots (from front to back). The harness assembly should slide out the back of the child restraint. Make sure not to disassemble the 3-bar metal bracket that fastens the harness assembly together.
6. Remove the cover by lifting the edges of the cover over the shell of the child restraint.

### Refitting the Cover

- The cover, harness and pads can be reinstalled by the following the preceding instructions in reverse.

## FOR YOUR CHILD'S CONTINUED SAFETY

Although child restraint systems undergo testing and evaluation, it is possible that a child restraint could be recalled.

In case of a recall, we can reach you only if we have your name and address, so please fill out the registration form to be on our recall list.

In order to properly register your child restraint system, you will need to provide the model number, serial number and date of manufacture. This information is printed on the registration card can be found on a white label located on the back of the child restraint system.

This registration is only applicable to child restraint systems purchased in the United States.

## WARRANTY

Inspired by Drive warrants this product to be free of defects in material and workmanship. Our obligation under this warranty is limited to repair or replacement of any part or entire unit at our option for a period of one year from date of delivery to the original purchaser. The warranty does not include cost of inconvenience, property damage, misuse, abuse, crash or similar incidents. The warranty will not apply if product has been tampered with or repaired by unauthorized individuals.

